

# 鋼筋混凝土建築物補強及修復 參考圖說及解說研討會

## 植筋

主講人：蔡東和  
May 11, 2016



## 17TH STREET BRIDGE Canopy Failure Investigation

Atlanta, Georgia



## Canopy-Fence Structure

- Epoxy adhesive anchors
  - 7/8" diameter
  - 4 anchors per frame
  - Anchored to outside (south) face of concrete parapet through flange in column assembly
  - No specification for anchor material or adhesive system
  - No specification for hole diameter or embedment depth
  - Sufficient embedment to develop tension service load of 4,000 lb. per anchor

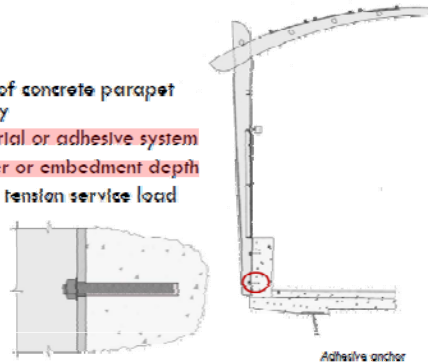

## Visual Assessment – Anchor Holes

- Epoxy observations
  - Generally bonded to substrate concrete
  - Frequent voids/air pockets, especially in back 1.5" of hole
  - Varied in color
    - Opaque dark gray
    - Opaque light gray
    - Translucent brown
  - Wet epoxy components extracted at 3 locations



Wet epoxy component extracted from bridge hole 200

## Conclusion

- Primary causes of canopy failure related to epoxy anchor adhesive:
  - Poor resistance to long-term creep
  - Sustained tensile loading
- Secondary causes
  - Disproportionate mixing of adhesive components
  - Incomplete mixing of adhesive components
  - Inclusion of air voids
  - High temperature in service



GEORGIA DEPARTMENT OF TRANSPORTATION

### Press Release

For Immediate Release  
Friday, January 20, 2012

Contact: David Spear or Jill Goldberg  
(404) 631-1825 or (404) 631-1828

Atlanta...  
17<sup>th</sup> Street Bridge Fence Canopy Failure Investigation Report Released

ATLANTA – The failure last summer of a portion of a decorative fence canopy on the 17<sup>th</sup> Street Bridge above Interstate Highways 75 and 85 here was an inevitable result of circumstances unknown at

WJE determined that the epoxy used to secure the canopy's anchor bolts to the bridge wall lost adhesion under sustained tension – a phenomenon known as "creep" – that was first discovered in 2006. (The fence canopy was installed in 2004.) That creep allowed the anchor bolts to slowly, virtually imperceptibly, pull away from the wall until the structure fell. As it can be almost impossible to detect creep during an inspection process, WJE concluded it simply was a matter of time before the canopy failed. The firm also found that the failure was accelerated by "poor mixing...poor proportioning (and) ...incomplete filling" of the epoxy by Georgia DOT's contractor.

"We are so very fortunate that there were no injuries or worse and just minor property damage that night," DOT Commissioner Keith Golden said, "so very, very fortunate. We learned from this and we already have begun to implement changes."

Among those changes are an ongoing prioritized inspection of structures that utilize epoxy to secure appearances such as fence and utility conduit to bridge structures and an immediate prohibition on future epoxy use for such anchors.

"This was a disturbing incident, obviously," DOT Chief Engineer Gerald Ross said. "But it was an anomaly in so many respects. Georgia's roads and bridges are safe and it is important that our citizens know that."

- “Big Dig, Boston” accident in 2006

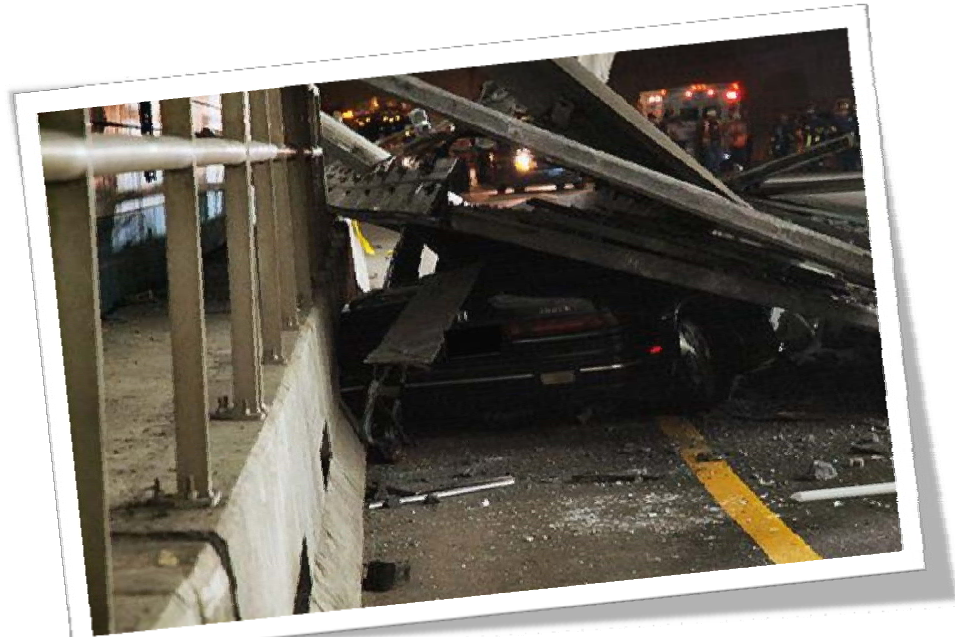

- “Big Dig, Boston” accident in 2006



- “Big Dig, Boston” accident in 2006



## 簡報大綱

- 植筋設計
- 植筋施工步驟
- 植筋技術
- 植筋施工之品質管理
- 植筋參考圖
- 常見之問題



# 植筋設計

## 植筋設計依據

- 完整
  - ACI 318-11 Appendix D Anchoring to Concrete
  - ICC-ES ESR-2322 report for Hilti HIT-RE 500-SD
- 過渡
  - ACI 318-05 Appendix D Anchoring to Concrete
  - (現行混凝土設計規範 附篇D 錨栓應用混凝土結構)
  - ICC-ES ESR-2322 report for Hilti HIT-RE 500-SD

## 錨栓種類

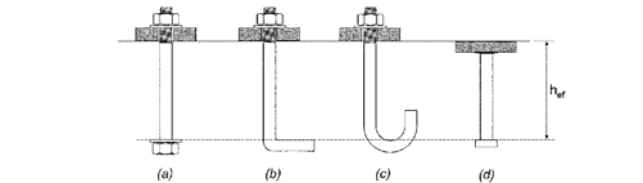

(A) 預埋式錨栓

(a) 六角頭螺栓含墊片 (b) L-型錨栓 (c) J形錨栓 (d) 焊接剪力釘

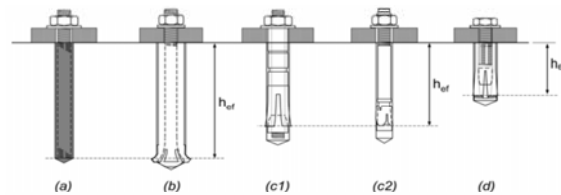

(B) 後置式錨栓

(a) 黏著式錨栓 (b) Undercut型錨栓 (c1) 扭力控制膨脹錨栓 (c2) Stud型 (d) 位移控制型膨脹錨栓

## 拉力破壞模式

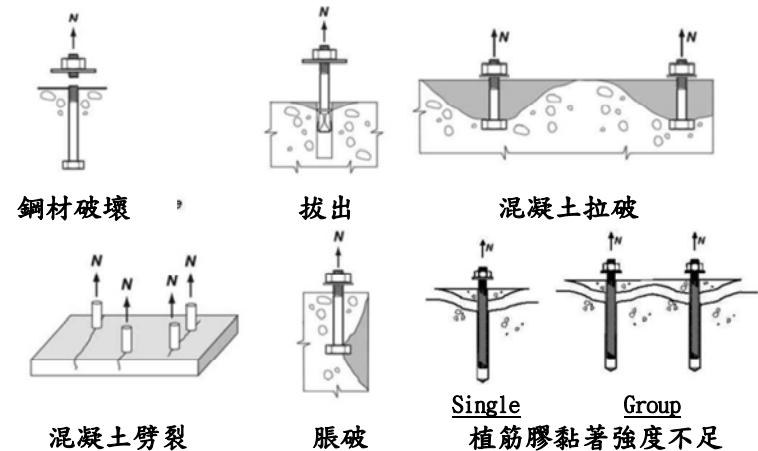

Single Group  
植筋膠黏著強度不足  
(植筋特有之破壞模式)

拉力



## 剪力破壞模式

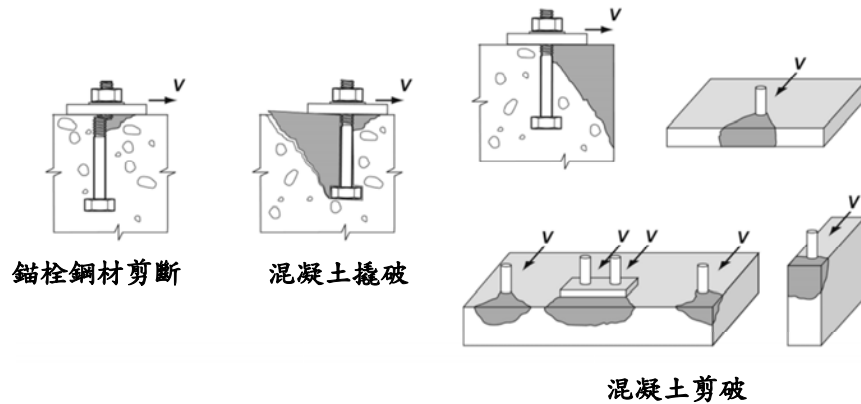

剪力

## Anchor Bolt 設計

The stress cone checks rely upon the strength of plain concrete for developing the anchor rods and typically apply when columns are supported directly on spread footings, concrete mats or pile caps. However, in some instances the projected area of the stress cones or overlapping stress cones is extremely limited due to edge constraints. Consequently the tensile strength of the anchor rods cannot be fully developed with plain concrete. This is often the case with concrete piers. In these instances, steel reinforcement in the concrete is used to carry the force from the anchor rods. This reinforcement often doubles as the reinforcement required to accommodate the tension and/or bending forces in the pier. **The reinforcement must be sized and developed for the required tensile capacity of the anchor rods on both sides of the potential failure plane described in Figure 9.1.4. The anchor rod embedment lengths are determined from the required development lengths for this reinforcing steel. Hooks or bends can be added to this reinforcement to minimize development length in the breakout cone.**

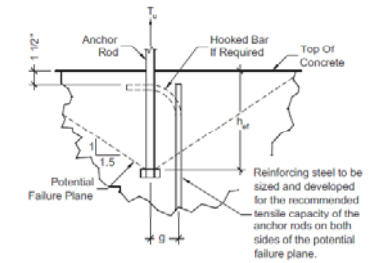

Fig. 9.1.4 The Use of Steel Reinforcement for Developing Anchor Rods

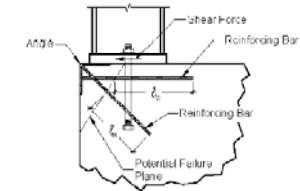

Fig. 9.2.3 Concrete Reinforcement to Improve Shear Capacity Where Edge Distance is Limited

## 錨栓強度計算

### • 拉力

- 錨栓鋼材拉力強度  $N_{sa} = A_s F_y$
- 混凝土拉破強度  $N_{cb}$
- 錨栓拔出強度  $N_{pn}$  錨栓無擴頭，無本項強度
- 混凝土邊緣脹破強度  $N_{sb}$  適用於有擴頭之錨栓，故不考慮這項強度
- 植筋膠之黏著強度  $N_a$  (ACI 318-11才有規定)

### • 剪力

- 錨栓鋼材剪力強度  $V_{sa}$
- 混凝土剪破強度  $V_{cb}$
- 混凝土撬破強度  $V_{cp}$

## 錨栓鋼材拉力強度

$$\text{Min}(\phi N_{cb}, \phi N_a) = A_s \cdot f_y$$

↑ 混凝土拉破強度  
↑ 植筋膠之黏著強度  
← 錨栓鋼材拉力強度

$A_s$  為受拉鋼筋之斷面積， $f_y$  為鋼筋之規定降伏強度

$\phi$  強度折減因數

- 依照國家地震中心對校舍補強工程之品質管制要求，植筋深度應該足夠使植入之鋼筋能承受不小於鋼筋規定強度之拉力。

依照Table D.5.5.2決定 $\tau_{cr}$

**TABLE D.5.5.2 — MINIMUM CHARACTERISTIC BOND STRESSES\*†**

Installation and service environment	Moisture content of concrete at time of anchor installation	Peak in-service temperature of concrete, °F	$\tau_{cr}$ , psi	$\tau_{un-cr}$ , psi
Outdoor	Dry to fully saturated	175	200	650
Indoor	Dry	110	300	1000

\*Where anchor design includes sustained tension loading, multiply values of  $\tau_{cr}$  and  $\tau_{un-cr}$  by 0.4.

†Where anchor design includes earthquake loads for structures assigned to Seismic Design Category C, D, E, or F, multiply values of  $\tau_{cr}$  by 0.8 and  $\tau_{un-cr}$  by 0.4.

可依ACI355.4試驗決定 $\tau_{cr}$

bond stresses. Because this effect is highly product dependent, design of anchors to be installed in core drilled holes should adhere to the product-specific characteristic bond stresses established through testing in accordance with ACI 355.4.

Characteristic bond stresses associated with qualified adhesive anchor systems for a specific set of installation and use conditions may substantially exceed the minimum values provided in Table D.5.5.2. For example, 1/2 in. to 3/4 in. diameter anchors installed in impact-drilled holes in dry concrete where use is limited to indoor conditions in uncracked concrete as described above may exhibit characteristic bond stresses,  $\tau_{un-cr}$  in the range of 2000 to 2500 psi.

**355.4-11: Qualification of Post-Installed Adhesive Anchors in Concrete and Commentary**

以符合ACI355.4之試驗決定 $\tau_{cr}$

TABLE 25—BOND STRENGTH DESIGN INFORMATION FOR U.S. CUSTOMARY UNIT REINFORCING BARS IN HOLES DRILLED WITH A HAMMER DRILL AND CARBIDE BIT<sup>1</sup>

DESIGN INFORMATION	Symbol	Units	Bar size								
			#3	#4	#5	#6	#7	#8	#9	#10	
Temperature range A <sup>2</sup>	Characteristic bond strength and minimum anchor embedment in cracked concrete	$f_{bc}$	1,090	1,075	1,045	1,000	915	855	800	730	
		$f_{bc,min}$	(7.5)	(7.4)	(7.2)	(6.9)	(6.3)	(5.9)	(5.5)	(5.0)	
	Characteristic bond strength and minimum anchor embedment in uncracked concrete	$f_{bc}$	2,265	2,235	2,145	2,065	2,000	1,945	1,900	1,860	
		$f_{bc,min}$	(15.6)	(15.4)	(14.8)	(14.3)	(13.8)	(13.4)	(13.1)	(12.8)	
Temperature range B <sup>3</sup>	Characteristic bond strength and minimum anchor embedment in cracked concrete <sup>4</sup>	$f_{bc}$	444	431	379	345	316	294	276	260	
		$f_{bc,min}$	(3.1)	(3.0)	(2.6)	(2.4)	(2.2)	(2.0)	(1.9)	(1.8)	
	Characteristic bond strength and minimum anchor embedment in uncracked concrete <sup>4</sup>	$f_{bc}$	791	772	739	714	691	672	656	643	
		$f_{bc,min}$	(5.4)	(5.3)	(5.1)	(4.8)	(4.6)	(4.5)	(4.4)	(4.4)	
Permissible installation conditions	Dry concrete	$k_{cr}$	0.65	0.65	0.65	0.65	0.55	0.55	0.55	0.55	
		$k_{un-cr}$	0.55	0.55	0.45	0.45	0.45	0.45	0.45	0.45	
	Water-saturated concrete	$k_{cr}$	1.00	1.00	1.00	1.00	1.00	0.99	0.97	0.94	
		$k_{un-cr}$	0.45	0.45	0.45	0.45	0.45	0.45	0.45	0.45	
	Water-filled hole	$k_{cr}$	1.00	1.00	0.96	0.91	0.87	0.84	0.82	0.79	
		$k_{un-cr}$	0.45	0.45	0.45	0.45	0.45	0.45	0.45	0.45	
	Underwater application	$k_{cr}$	0.95	0.94	0.94	0.93	0.92	0.92	0.92	0.91	
		$k_{un-cr}$	0.45	0.45	0.45	0.45	0.45	0.45	0.45	0.45	

For #3: 1 inch @ 25.4 mm, 1 BF = 4,448 N, 1 psi = 0.006897 MPa.  
For pound-inch units: 1 inch = 0.03937 meter, 1 lb = 0.2248 BF, 1 MPa = 145.0 psi.  
Bond strength values (normalized to concrete compressive strength) in the range 2,500 psi (1.7) to 4,500 psi (3.1) are 145.0 psi.  
1,000 psi. Tabulated characteristic bond strengths may be increased by 6 percent. For the range 4,500 psi (3.1) to 8,500 psi (5.9), tabulated characteristic bond strengths may be increased by 10 percent.  
2 Characteristic bond strengths are for sustained loads including dead and live loads. For load combinations consisting of short-term loads only such as wind and seismic, bond strengths may be increased 40 percent.  
3 Temperature range A: Maximum short-term temperature = 110°F (43°C); Maximum long-term temperature = 90°F (32°C).  
4 Temperature range B: Maximum short-term temperature = 102°F (39°C); Maximum long-term temperature = 100°F (38°C).  
Short-term elevated concrete temperatures are those that occur over brief intervals, e.g., as a result of diurnal cycling. Long-term concrete temperatures are roughly constant over significant periods of time.  
5 For structures assigned to Seismic Design Categories C, D, E or F, bond strength values must be multiplied by  $k_{seis} = 0.85$ .

**HILTI HIT-RE 500-SD ADHESIVE ANCHORS IN CONCRETE**  
Compliance with 2009 International Building Code® (2009 IBC)

植筋在開裂混凝土之握裹力

DESIGN INFORMATION	Symbol	Units	Bar size								
			#3	#4	#5	#6	#7	#8	#9	#10	
Temperature range A <sup>2</sup>	Characteristic bond strength and minimum anchor embedment in cracked concrete	$\tau_{k,cr}$	1,090	1,075	1,045	1,000	915	855	800	730	
		$\tau_{k,cr}$	(7.5)	(7.4)	(7.2)	(6.9)	(6.3)	(5.9)	(5.5)	(5.0)	
	Characteristic bond strength and minimum anchor embedment in uncracked concrete	$\tau_{k,un-cr}$	2,265	2,235	2,145	2,065	2,000	1,945	1,900	1,860	
		$\tau_{k,un-cr}$	(15.6)	(15.4)	(14.8)	(14.3)	(13.8)	(13.4)	(13.1)	(12.8)	

<sup>1</sup> Bond strength values correspond to concrete compressive strength in the range 2,500 psi  $\leq f'_c \leq$  4,500 psi. For the range 4,500 psi  $< f'_c \leq$  6,500 psi, tabulated characteristic bond strengths may be increased by 6 percent. For the range 6,500 psi  $< f'_c \leq$  8,000 psi, tabulated characteristic bond strengths may be increased by 10 percent.

<sup>2</sup> Characteristic bond strengths are for sustained loads including dead and live loads. For load combinations consisting of short-term loads only such as wind and seismic, bond strengths may be increased 40 percent.

<sup>3</sup> Temperature range A: Maximum short term temperature = 110°F (43°C), Maximum long term temperature = 80°F (26°C).

Temperature range B: Maximum short term temperature = 162°F (72°C), Maximum long term temperature = 110°F (43°C). Short term elevated concrete temperatures are those that occur over brief intervals, e.g., as a result of diurnal cycling. Long term concrete temperatures are roughly constant over significant periods of time.

<sup>4</sup> For structures assigned to Seismic Design Categories C, D, E or F, bond strength values must be multiplied by  $\phi_{N,seis} = 0.65$ .

## 植筋深度 ( $f'_c = 175 \sim 320 \text{ kg/cm}^2$ )

達到鋼筋降伏強度之黏結式錨栓埋入深度 (以HILTI RE500為例)

Bond Stress 依照 ESR-2333 TABLE 25 混凝土抗壓強度  $f'_c = 175 \text{ kgf/cm}^2$

	#3	#4	#5	#6	#7	#8	#9	#10
$\tau_{cr}$ (crack)psi	1090	1075	1046	1000	915	855	900	730
$h_{ef}$ (cm) SD280	11.6	16.0	20.4	25.2	32.2	39.7	42.4	59.8
$h_{ef}$ (cm) SD420	17.3	24.0	30.5	37.8	48.3	59.5	63.6	89.6

Bond Stress 依照 ACI 318-11 Table D5.2.2

	#3	#4	#5	#6	#7	#8	#9	#10
$\tau_{cr}$ (crack)psi indoor	300	300	300	300	300	300	300	300
$h_{ef}$ (cm) SD280	42.0	57.2	71.0	84.0	98.1	113.1	127.2	145.4
$h_{ef}$ (cm) SD420	63.0	85.9	106.5	125.9	147.2	169.6	190.8	218.1

備註: 1. 黏結式錨栓強度計算時假設間距及邊距大於2倍有效埋深

2. 鋼筋強度  $A_s F_y$

3. 混凝土拉破強度 · 折減係數  $\phi = 0.75$

3. 黏結式錨栓握裹強度 · 折減係數  $\phi = 0.75$

3. 混凝土抗壓強度  $f'_c = 175 \sim 320 \text{ kgf/cm}^2$

## 植筋深度 ( $f'_c = 100, 125$ 或 $150 \text{ kg/cm}^2$ )

Bond Stress 依照 ESR-2333 TABLE 25 混凝土抗壓強度  $f'_c = 150 \text{ kg/cm}^2$

	#3	#4	#5	#6	#7	#8	#9	#10
$h_{ef}$ (cm) SD280	12.5	17.3	22.0	27.2	34.8	42.8	45.8	64.5
$h_{ef}$ (cm) SD420	18.7	25.9	33.0	40.8	52.1	64.3	68.7	96.8

Bond Stress 依照 ESR-2333 TABLE 25 混凝土抗壓強度  $f'_c = 125 \text{ kg/cm}^2$

	#3	#4	#5	#6	#7	#8	#9	#10
$h_{ef}$ (cm) SD280	13.7	18.9	24.1	29.8	38.1	46.9	50.2	70.7
$h_{ef}$ (cm) SD420	20.5	28.4	36.1	44.7	57.1	70.4	75.3	106.0

Bond Stress 依照 ESR-2333 TABLE 25 混凝土抗壓強度  $f'_c = 100 \text{ kg/cm}^2$

	#3	#4	#5	#6	#7	#8	#9	#10
$h_{ef}$ (cm) SD280	15.3	21.1	26.9	33.3	42.6	52.5	56.1	79.0
$h_{ef}$ (cm) SD420	22.9	31.7	40.4	50.0	63.8	78.7	84.1	118.6

植筋施工



# 植筋施工

以下之施工步驟僅供參考，實際施工應嚴格遵守原廠安裝指示書(Manufacturer's Printed Installation Instructions, MPII)所規定之步驟。

1. 檢查黏結式錨栓藥劑之廠牌、型號、適用之植筋方向、適用之氣溫與濕度等，是否符合本工程之要求。
2. 檢查黏結式錨栓藥劑是否在有效期限內。
3. 黏結式錨栓之施工需要由合格之專業技術人員施做。
4. 鑽孔位置：須按照設計圖指定之位置施做。
5. 為避免鑽到原有鋼筋，黏結式錨栓鑽孔前應使用鋼筋探測器或可行之方法確認原結構之鋼筋位置，並繪製預定鑽孔位置於原混凝土表面，經由與工程司會勘核可後方可施工。
6. 鑽孔深度：依照設計圖指定之深度施做，由於各廠牌間黏結式錨栓藥劑成分不同且既有結構物之混凝土強度亦有差異，承包商施工前應會同監造單位須進行施工前拉拔試驗，並提出書面文件及試驗相片以供確認。
7. 若黏結式錨栓安裝在鋼筋混凝土構件時，不可以整根鋼筋都位於混凝土保護層。
8. 鑽孔過程若遇鋼筋，不可破壞或鑽斷，若在未鑽到設計埋置深度就遇到鋼筋，則此鑽孔應予以廢棄，另行鑽孔，廢孔應以無收縮水泥砂漿填實。
9. 鑽孔完畢後應原廠安裝指示書(Manufacturer's Printed Installation Instructions, MPII)徹底以高壓空氣及毛刷清除孔內灰屑，清除過程中應注意避免造成空氣汙染。
10. 將黏結式錨栓藥劑裝入原廠指定之注射器，以裝有混合器之注射頭深入孔底緩緩將黏結式錨栓藥劑打入孔內，邊打邊退，直到藥劑量足夠為止。
11. 將鋼筋慢慢旋入孔內至底部，且可目視藥劑外溢，不可將鋼筋直接插入，以避免鋼筋與孔壁間殘留空隙。
12. 黏結式錨栓施作後之硬化過程中，應避免碰觸且不得矯正鋼筋，待硬化完成後，始可進行負載或後續之施工。
13. 施工完成後，須會同監造單位進行現場拉拔試驗，並提送完整紀錄供核備。

# 植筋技術

# 原廠安裝指示書 (manufacturer's printed installation instructions (MPII))

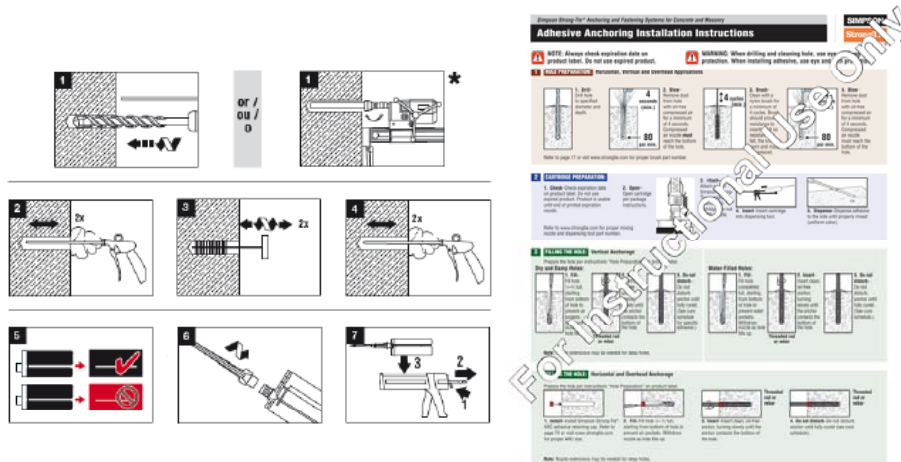

# 清孔工具



## 清孔之重要性



## 清孔之重要性

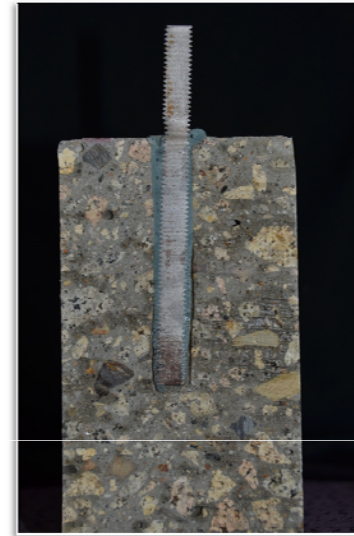

## 先擠出混合不良之植筋膠



## 向下植筋 - 要從孔之最內部開始灌

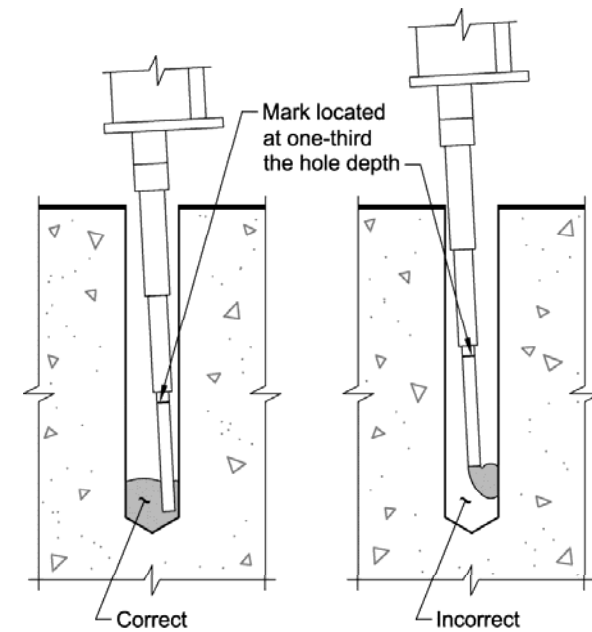

## 向上植筋 - 要從孔之最內部開始灌 (Hilti 活塞)

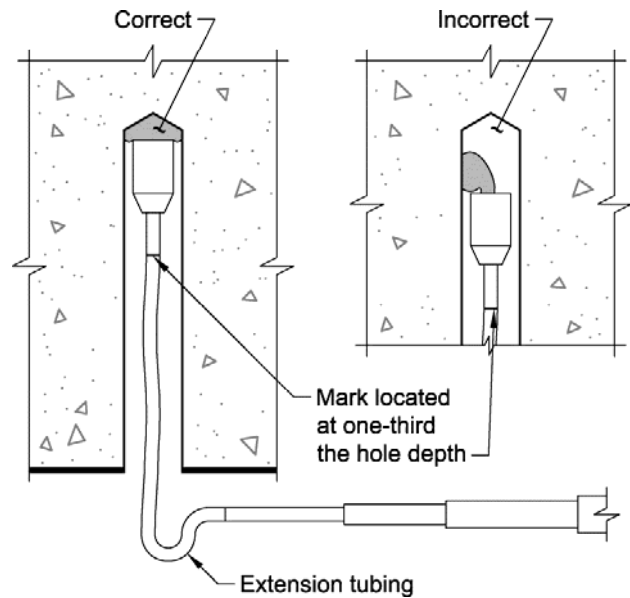

## 向上植筋 - 要從孔之最內部開始灌 (無活塞式)

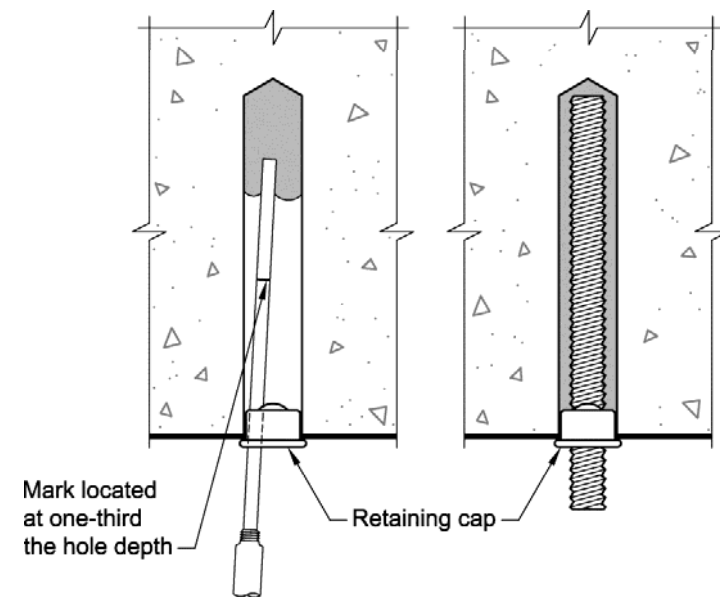

## 向上植筋與孔塞

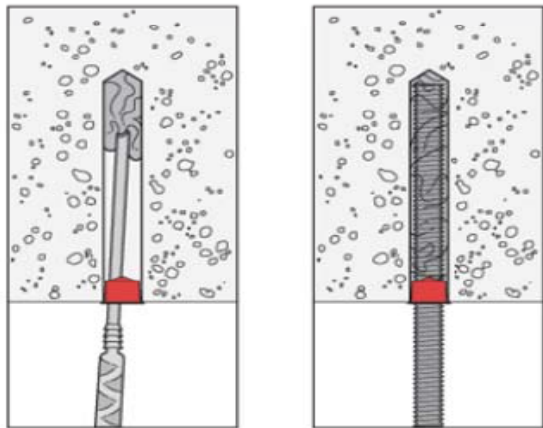

The "X" cut in the cap allows the mixing nozzle and insert to pass through, while containing the adhesive in the hole.

## 向上植筋與孔塞





# 向上植筋與孔塞



# 向上植筋與孔塞



# 向上植筋與孔塞



# 活塞 – 向上植筋時，輔助將孔灌滿

A piston plug is a device used to help uniformly fill overhead holes with adhesive from the deepest part of the hole.  
Pg. 59, Para. 2



## 常見問題 – 植筋膠中空



孔塞 –  
防止水平或向上植筋時，植筋膠流出同時固定錨栓位置



## 安全防護裝置



植筋施工之品質管理

## 植筋拉拔強度試驗標準

- ASTM E488 Standard Test Methods for Strength of Anchors in Concrete Elements (ASTM, 2010)
- 中國國家標準CNS13975 A3370帷幕牆混凝土錨件強度試驗法 (CNS, 1997)。

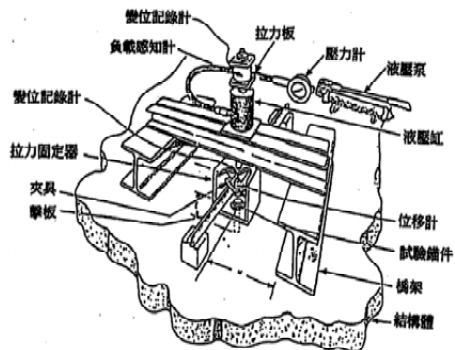

## 植筋施工之品質管理

- 由通過TAF或經監造單位認可之試驗單位
- 依據
  - ASTM E488 Standard Test Methods for Strength of Anchors in Concrete Elements
  - 中國國家標準CNS13975 A3370帷幕牆混凝土錨件強度試驗法
- 施工前拉拔試驗：
  - 依設計之埋深安裝黏結式錨栓，以1.25 為拉拔力，各號數在工地試作3支。
- 施工後安裝品質試驗：
  - 測試拉力為1.0，每樓層各種尺寸每100支抽驗1支，且不得少於3支。若為補強工程，因黏結式錨栓之品質對補強成果之影響極大，建議每一補強構件至少要抽驗1支。測試過程中若出現失敗樣本，則同一批樣本改以25%比例進行安全測試，若全部合格，則該批黏結式錨栓視為合格，原有之失敗黏結式錨栓由承包商無償補做；若25%之樣本中有任一支不合格，則該批黏結式錨栓全部測試，若出現有任何不合格，黏結式錨栓視同失效，後續依監造單位指示辦理補救措施。

## 試驗設備

- 油壓千斤頂、手動幫浦、校正報告、鋼筋夾片。
- 油壓千斤頂及手動幫浦須經國家標準局認證通過之檢驗單位校正，並檢附有效校正期限為一年內之校正報告。

植筋拉拔測試報告

試樣編號	鋼筋直徑 (mm)	錨固深度 (mm)	試驗日期	試驗人員	備註
101	12	100	10/10	張三	
102	12	100	10/10	張三	
103	12	100	10/10	張三	
104	12	100	10/10	張三	
105	12	100	10/10	張三	
106	12	100	10/10	張三	
107	12	100	10/10	張三	
108	12	100	10/10	張三	
109	12	100	10/10	張三	
110	12	100	10/10	張三	

千斤頂荷重比對測試報告

荷重 (kg)	油壓管壓力 (MPa)	油壓管直徑 (mm)	油壓管長度 (mm)	油壓管材料	油壓管規格
100	0.10	12	100	304	12x100
200	0.20	12	100	304	12x100
300	0.30	12	100	304	12x100
400	0.40	12	100	304	12x100
500	0.50	12	100	304	12x100
600	0.60	12	100	304	12x100
700	0.70	12	100	304	12x100
800	0.80	12	100	304	12x100
900	0.90	12	100	304	12x100
1000	1.00	12	100	304	12x100

## 試驗步驟

- 確定試驗鋼筋周圍平面平坦且與黏結式錨栓垂直(正交)，將腳座及夾具固定於受測樣本上，再套入千斤頂。測試時須裝置腳座以符合ASTM E488 Standard Test Methods for Strength of Anchors in Concrete Elements[3.1-5]或中國國家標準CNS13975 A3370帷幕牆混凝土錨件強度試驗法之裝置規定。
- 將手動幫浦油壓管接上千斤頂，並旋緊閥門。
- 確定油壓表歸零後由手動幫浦徐徐加壓，直到試驗拉力。
- 紀錄並拍照存證後打開閥門，解除拉力，試驗完成。

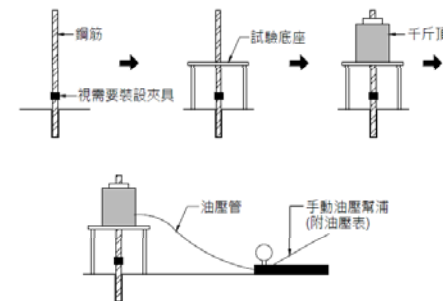



## ASTM E488 拉拔試驗-裝置

千斤頂 壓力計

支架



## ASTM E488 拉拔試驗-流程



## Hilti 之試驗裝置



## 施工抽查 - 植筋鑽孔深度





## 植筋參考圖

**植筋施工**

**一、材料：**

- 1. 植筋規範：
- (1) 植筋規範由業主提供植筋規範圖則，內容應至少包含：
- (2) 植筋規範圖則
- (3) 植筋規範圖則之標識：型號、直徑
- (4) 植筋規範圖則之安裝方式：向下、水平或向上
- (5) 植筋規範圖則之植筋長度 (Manufacturer's Printed Installation Instructions, MPI)
- 2. 規範：依設計圖則之要求

**二、植筋位置與深度：**

- 植筋位置與深度之植筋埋入深度 (混凝土抗壓強度  $f_c = 175 \text{ kg/cm}^2$ )  
 植筋埋入深度之植筋埋入深度 (以 HBLT RE500 計算)  
 Bond Stress 依照 ESR-2333 TABLE 25 混凝土抗壓強度  $f_c = 175 \text{ kg/cm}^2$

	A1	A2
$f_{tk}(MPa)$	200	250
$f_{tk}(MPa)$ S0290	300	300
$f_{tk}(MPa)$ S0420	300	300

註：以上之埋入深度係指下列之假設計算

- 植筋埋入深度計算時有鉛垂度及偏距大於 2 倍有效埋深
- 植筋埋入 Asfy
- 混凝土抗壓強度折減係數： $\alpha = 0.75$
- 植筋埋入有效埋深折減係數： $\beta = 0.75$
- 混凝土抗壓強度  $f_c = 175 \sim 320 \text{ kg/cm}^2$

- 植筋位置與深度之植筋埋入深度 (混凝土抗壓強度  $f_c < 175 \text{ kg/cm}^2$ )  
 Bond Stress 依照 ESR-2333 TABLE 25 混凝土抗壓強度  $f_c = 150 \text{ kg/cm}^2$

	A1	A2
$f_{tk}(MPa)$ S0290	300	300
$f_{tk}(MPa)$ S0420	300	300

Bond Stress 依照 ESR-2333 TABLE 25 混凝土抗壓強度  $f_c = 125 \text{ kg/cm}^2$

	A1	A2
$f_{tk}(MPa)$ S0290	300	300
$f_{tk}(MPa)$ S0420	300	300

Bond Stress 依照 ESR-2333 TABLE 25 混凝土抗壓強度  $f_c = 100 \text{ kg/cm}^2$

	A1	A2
$f_{tk}(MPa)$ S0290	300	300
$f_{tk}(MPa)$ S0420	300	300

**三、植筋施工步驟：**

以下之施工步驟應供參考，實際施工應遵守原廠安裝指南 (Manufacturer's Printed Installation Instructions, MPI) 所指定之步驟。

- 植筋位置與深度之標識：型號、直徑、埋入之植筋方向、植筋之深度與角度、是否預先植入之要求。
- 植筋位置與深度之有效期間內。
- 植筋之施工應由合格之專業技術人員執行。
- 植筋位置：植筋位置應由合格之專業技術人員指定。
- 植筋位置與深度之有效期間內。
- 植筋位置與深度之有效期間內。
- 植筋位置與深度之有效期間內。
- 植筋位置與深度之有效期間內。

**植筋拉拔試驗：**

植筋拉拔試驗之目的在於驗證植筋與混凝土間之黏結力，並確保植筋在設計之荷載下能正常運作。

**試驗目的：**

- 試驗目的：
- 試驗目的：
- 試驗目的：

**試驗裝置：**

植筋拉拔試驗之裝置應符合下列之要求：

- 試驗裝置應符合下列之要求：
- 試驗裝置應符合下列之要求：
- 試驗裝置應符合下列之要求：

**試驗步驟：**

- 植筋拉拔試驗之準備工作：
- 植筋拉拔試驗之執行：
- 植筋拉拔試驗之記錄：

**植筋拉拔試驗之注意事項：**

- 植筋拉拔試驗之注意事項：
- 植筋拉拔試驗之注意事項：
- 植筋拉拔試驗之注意事項：
- 植筋拉拔試驗之注意事項：

**植筋拉拔試驗之圖則：**



## 二、植筋埋置深度：

1. 達到降伏強度之植筋埋入深度 (混凝土抗壓強度 $f'c > 175 \text{kgf/cm}^2$ )  
達到鋼筋降伏強度之黏結式錨栓埋入深度 (以HILTI RE500計算)  
Bond Stress 依照ESR-2333 TABLE25混凝土抗壓強度 $f'c = 175 \text{kgf/cm}^2$

	#3	#4	#5
$\tau_{cr}(\text{crack})$ psi	1090	1075	1046
$h_{ef}(\text{cm})$ SD280	11.6	16.0	20.4
$h_{ef}(\text{cm})$ SD420	17.3	24.0	30.5

註：以上之埋入深度係依下列之假設計算

1. 黏結式錨栓強度計算時假設間距及邊距大於2倍有效埋深
2. 鋼筋強度  $A_s F_y$
3. 混凝土拉破強度, 折減係數  $\phi = 0.75$
4. 黏結式錨栓握裹強度, 折減係數  $\phi = 0.75$
5. 混凝土抗壓強度  $f'c = 175 \sim 320 \text{kgf/cm}^2$

2. 達到降伏強度之植筋埋入深度 (混凝土抗壓強度 $f'c < 175 \text{kgf/cm}^2$ )  
Bond Stress 依照ESR-2333 TABLE25混凝土抗壓強度 $f'c = 150 \text{kgf/cm}^2$

	#3	#4	#5
$h_{ef}(\text{cm})$ SD280	12.5	17.3	22.0
$h_{ef}(\text{cm})$ SD420	18.7	25.9	33.0

- Bond Stress 依照ESR-2333 TABLE25混凝土抗壓強度 $f'c = 125 \text{kgf/cm}^2$

	#3	#4	#5
$h_{ef}(\text{cm})$ SD280	13.7	18.9	24.1
$h_{ef}(\text{cm})$ SD420	20.5	28.4	36.1

- Bond Stress 依照ESR-2333 TABLE25混凝土抗壓強度 $f'c = 100 \text{kgf/cm}^2$

	#3	#4	#5
$h_{ef}(\text{cm})$ SD280	15.3	21.1	26.9
$h_{ef}(\text{cm})$ SD420	22.9	31.7	40.4

## 三、植筋施工之步驟

以下之施工步驟僅供參考，實際施工應嚴格遵守原廠安裝指示書

- (Manufacturer's Printed Installation Instructions, MPII)所規定之步驟。
1. 檢查植筋劑之廠牌、型號、適用之植筋方向、適用之氣溫與濕度，是否符合本工程之要求。
  2. 檢查植筋劑是否在有效期限內。
  3. 植筋之施工需要由合格之專業技術人員施做。
  4. 鑽孔位置：須按照設計圖指定之位置施做。
  5. 為避免鑽到原有鋼筋，植筋鑽孔前應使用鋼筋探測器或可行之方法確認原結構之鋼筋位置，並繪製預定鑽孔位置於原混凝土表面，經由與工程司會勘核可後方可施工。
  6. 鑽孔深度：依照設計圖指定之深度施做，由於各廠牌間植筋劑成分不同且既有結構物之混凝土強度亦有差異，承包商施工前應會同監造單位須進行施工前拉拔試驗，並提出書面文件及試驗相片以供確認。
  7. 若植筋安裝在鋼筋混凝土構件時，不可以整根鋼筋都位於混凝土保護層。
  8. 鑽孔過程若遇鋼筋，不可破壞或鑽斷，若在未鑽到設計埋置深度就遇到鋼筋，則此鑽孔應予以廢棄，另行鑽孔，廢孔應以無收縮水泥砂漿填實。
  9. 鑽孔完畢後應原廠安裝指示書(Manufacturer's Printed Installation Instructions, MPII)徹底以高壓空氣及毛刷清除孔內灰屑，清除過程中應注意避免造成空氣汙染。
  10. 將植筋劑裝入原廠指定之注射器，以裝有混合器之注射頭深入孔底緩緩將植筋劑打入孔內，邊打邊退，直到劑量足夠為止。
  11. 將鋼筋慢慢旋入孔內至底部，且可目視劑劑外溢，不可將鋼筋直接插入，以避免鋼筋與孔壁間殘留空隙。
  12. 植筋施作後之硬化過程中，應避免碰觸且不得矯正鋼筋，待硬化完成後，始可進行負載或後續之施工。
  13. 施工完成後，須會同監造單位進行現場拉拔試驗，並提送完整紀錄供核備。

## 四、植筋施工測試

1. 試驗目的：  
確認植筋施工之品質能符合設計要求
2. 試驗單位：  
拉拔試驗須由通過TAF或經監造單位認可之試驗單位執行
3. 試驗標準：  
依照ASTM E488 Standard Test Methods for Strength of Anchors in Concrete Elements或中國國家標準CNS13975 A3370惟幕牆混凝土錨件強度試驗法實施，並於每次試驗完畢，由試驗單位出具試驗結果報告，提送監造單位查核。

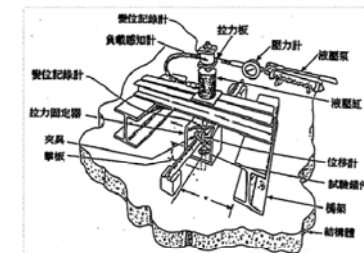

靜態試驗一般裝置示意圖(摘自CNS13975 A3370)



#### 4. 施工前拉拔試驗：

測試拉力依設計之埋深植筋完成後，以 $1.25 f_y$ 為拉力進行拉拔試驗，各號數在工地試作3支。

#### 5. 施工後安裝品質試驗：

測試拉力為 $1.0 f_y$ ，每樓層各種尺寸每100支抽驗1支，且不得少於3支。若為補強工程，因植筋之品質對補強成果之影響極大，建議每一補強構件至少要抽驗1支。測試過程中若出現失敗樣本，則同一批樣本改以25%比例進行安全測試，若全部合格，則該批植筋視為合格，原有之失敗植筋由承包商無償補做；若25%之樣本中有任一支不合格，則該批植筋全部測若出現有任何不合格，植筋視同失效，後續依監造單位指示辦理補救措施。

#### 6. 試驗設備：

植筋之拉拔試驗設備包括：油壓千斤頂、手動幫浦、鋼筋夾片、試驗腳座。其中油壓千斤頂及手動幫浦須經國家標準局認證通過之檢驗單位校正，並檢附有效校正期限為一年內之校正報告。

#### 7. 試驗步驟

- (1) 確定試驗鋼筋周圍平面平坦且與植筋垂直(正交)，將腳座及夾具固定於受測樣本上，再套入千斤頂。
- (2) 將手動幫浦油壓管接上千斤頂，並旋緊閥門。
- (3) 確定油壓表歸零後由手動幫浦徐徐加壓，直到試驗拉力。
- (4) 紀錄並拍照存證後打開閥門，解除拉力，試驗完成。

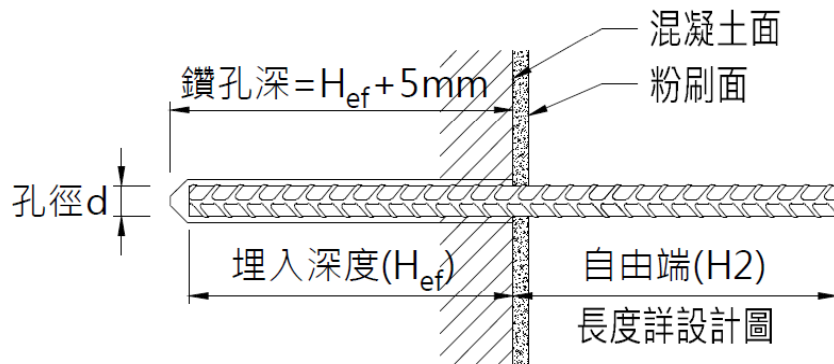
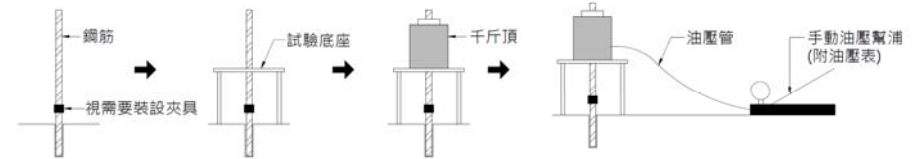

植筋長度詳圖 (1)

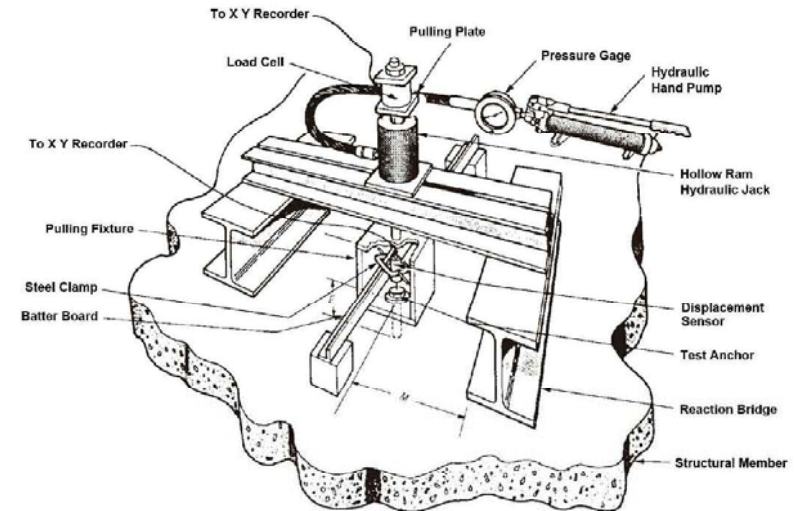

FIG. 1 Typical Static Tension Test Arrangement

試驗裝置圖 (節錄自 ASTM E488) (3)

# 常見之問題

補強設計所採用之混凝土現況抗壓強度	
樓層	補強設計所採用之混凝土現況抗壓強度(kgf/cm <sup>2</sup> )
B1F	(設計者填入強度)
1F	(設計者填入強度)
2F	(設計者填入強度)
3F	(設計者填入強度)

「提醒設計者之注意事項」  
 植筋之埋入深度計算之假設條件如下：若有不符合時，設計單位應做適當之修正，惟不得小於上表埋入深度。  
 a. 植筋強度可達到鋼筋之降伏強度。  
 b. 於混凝土之可能破壞面須有輔助鋼筋通過。  
 c. 安裝方式為低敏感度、高可靠度 $\phi=0.75$ 。  
 d. 各植筋有足夠之邊距及間距。

# 承包商常要求採用較短的錨錠深度施工

- 因為植筋深度除了依照植筋膠之黏著強度外，還考量了錨栓拉破、錨栓群強度折減、混凝土裂縫及其他安全係數，故通常試驗所得到的強度都會高出設計強度許多，但**不宜**因此採用較短的錨錠長度。

# 植筋膠未能充滿錨栓周圍

- 植筋若施作不良，除拉拔試驗外，幾乎不能由檢驗方式查出
- 植筋應由合格的專業技術人員施做，施做時**嚴格遵守原廠安裝指示書(MPII)**所規定之步驟。

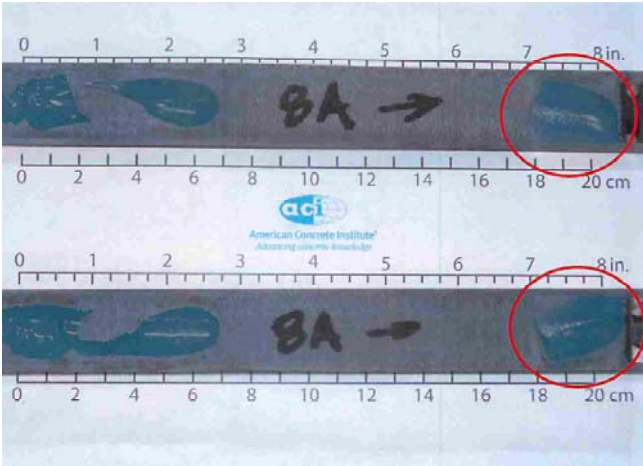

## 缺材料認證的機制 - 材料未被認證

- 目前國內並筋材料的國家標準，亦無認證制度，市場上之材料有進口材料也有國產材料，因缺乏標準，產品良莠不齊，監造單位通常只能以現場拉拔試驗做檢驗，但對於產品之耐久、耐厚、可靠度則無管理的依據。**應盡速建立植筋膠之認證標準及認證制度。**

## 無合格植筋技術人員認證機制 - 植筋技術人員良莠不齊

- 目前國內並無相關之認證制度及認證機構，建議可以**參考美國ACI-CRSI植筋技術人員認證(Adhesive anchor installer certification)制度**，建立國內的植筋技術人員的認證制度，以確保植筋工成之品質。

## 原廠安裝指示書 (manufacturer's printed installation instructions (MPII))

- 在國內銷售的各種植筋膠，並未嚴格要求安裝時要嚴格遵循原廠安裝指示書(MPII)規定之步驟，且進口廠牌並未提供中文之原廠安裝指示書(MPII)。應請各**供應植筋膠之廠商應負起責任教育植筋專業技術人員**能確實遵循原廠安裝指示書(MPII)規定之步驟進行植筋施做。

建議



## 建議

- 國內有關設計、施工、材料的規定都欠缺。
- 在沒有正式之相關規定時，設計時可以採用ACI318-11之規定計算，試驗則可依照ASTM E488 Standard Test Methods for Strength of Anchors in Concrete Elements 或CNS13975 A3370帷幕牆混凝土錨件強度試驗法進行。
- 植筋膠之握裹力，可以採用ICC的評估報告，但僅限於有在美國市場行銷的產品。
- 國內應盡速建立類似ACI 355.4 Qualification of Post-Installed Adhesive Anchors in Concrete 的試驗能力，以使在國內使用的產品能夠有適當的管理，設計單位也可以有適當的依循。

簡報結束，敬請指教